



INSTALLATION INSTRUCTIONS

Thank you for purchasing SRT-2® Spool Roll Tarp. Agri-Cover, Inc. proudly manufactured this tarp using superior quality materials and workmanship. With proper care, your tarp will provide years of service.

NOTICE TO INSTALLER: Even if familiar with product, read instructions prior to installation as improvements may be made without notice. Always handle components with care. If you have questions or problems, have serial number ready and call customer service. When done, these instructions must be given to the consumer.

NOTICE TO CONSUMER: Before using this product, read operating, maintenance and safety sections. Save these instructions for future reference.

FOR YOUR RECORDS

DATE PURCHASED: _____

WHERE PURCHASED: _____

TARP SERIAL NUMBER: _____

(Located at rear of tarp on stationary tube side)



AGRI-COVER, INC.

Questions? (800) 233-4655
agricover.com

PREPARATION

- Prior to tarp system assembly, park truck or trailer on level ground.
- Box must be square and straight, center must not be pulled together or spread apart.
- Before beginning, measure outer length and width of your box. Also measure length of tarp and width of the end caps to ensure you received the correct size.
- Remove or grind smooth any sharp edges or points contacting tarp and/or cables.
- Remove or reposition any interferences with tarp. If modifications to box are needed, consult box manufacturer.
- It may be necessary to use washers and nuts or other types of fasteners (not furnished) to ensure a solid anchor.
- Ensure box extension is secure by bolting in place on top of your box.

TOOLS NEEDED

- (2) Cardboard squares
- 9/16" Wrench
- 3/16" and 7/32" Allen wrenches
- Step ladders or scaffolding
- Drill with 5/16" and 3/8" bits
- Tape measure
- Impact wrench with 9/16" socket
- Hammer
- Threadlock adhesive
- Protective eyewear
- Cutting tool(s)
- Marking pencil

OPTIONAL TOOLS NEEDED

- Locking pliers
- Liner tool
- Heat source
- Phillips screwdriver
- 1/8" and 7/32" Drill bit
- Angle grinder

NOTE: Hardware appearance and components may vary.

⚠ CAUTION: Before drilling, ensure there are no hidden wires or gussets in line with holes to be drilled.

STAINLESS STEEL HARDWARE ONLY

⚠ CAUTION: To avoid galling of stainless steel hardware, use anti-galling spray, grease or lubricant on threads and avoid high speed when fastening. Do not use impact tools for stainless steel hardware.

A. Turn 3/8" x 1" non-stainless steel self-threading bolt in 5/16" hole to cut threads, then turn back out.

B. Turn 3/8" x 1" stainless steel bolt in for attachment. When possible, use stainless steel nuts and washers with these bolts.

SAFETY INFORMATION

▲ DANGER: Mounting replacement tarp to a structurally weak or damaged roll tube can result in serious injury or death.

Before installing replacement tarp, inspect mounting surface of roll tube. Be aware several mounting holes in close proximity may compromise roll tube strength and integrity. Ensure mounting location on roll tube provides adequate tarp support.

- Disconnect power before servicing tarp system or electrical components.
- Always use caution when operating tarp system.
- Ensure people and objects are clear of tarp system before and during operation.
- Instruct everyone who will operate tarp system on the proper procedures.
- Never allow children to operate or play with tarp system.
- Do not operate tarp system with box hoisted in elevated position.
- Ensure tarp system is fully open or fully closed before operating vehicle at highway speeds.
- Only operate tarp system when tarp is completely visible.
- Always refer to OEM instructions before installing electrical components.
- Do not use arm as a step.
- Remove snow or debris from top of tarp system before operating.
- End caps must be free from commodity. Commodity should not be piled higher than end caps.
- Do not directly spray motor or connections with a pressure washer.
- Ensure tarp system is fully open before unloading or loading.

NOTE: Safety and operating procedure decals provided with this kit should be kept clean at all times and replaced if worn, damaged, painted over or unreadable.

1: INSTALLING WEATHER SEAL TO END CAPS

NOTE: For best adhesion, ensure air and surface temperatures are above 60° F.

A. Test fit end cap, it should measure at least 1/2" or at most 1-1/2" narrower than top of box on both sides.

NOTE: Modify end cap if needed by notching overhang, removing protruding objects from box or trimming end cap width.

B. At each end, clean underside of end cap.

C. Align weather seal as shown. Test fit on end cap, adjust for optimum seal and trim if needed.

D. Peel protective backing then adhere seals to each side of end cap.

IMPORTANT: Sharp edges cause tarp damage not covered by warranty. Ensure end cap edges are installed tight to box. Always inspect areas where tarp closes around end caps and top corner of box and make required adjustments.

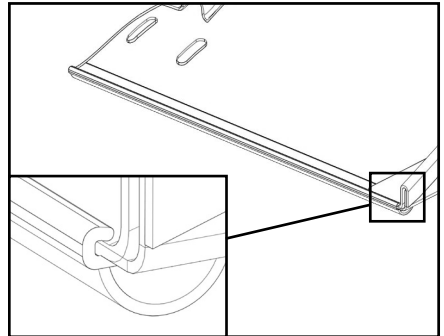
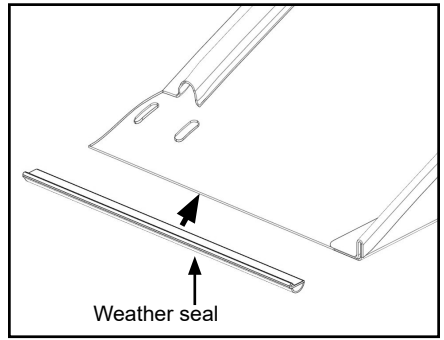
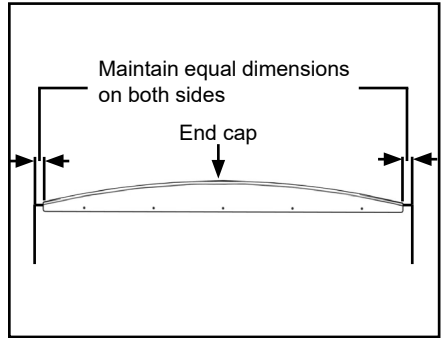

2: INSTALLING END CAPS

Perform one of the following to install end cap:

▲ CAUTION: Do not stand or walk on end cap.

NOTE: For stainless steel hardware, see page 2 for bolting procedures.

SIDE MOUNT

A. Center end cap on box. Press down and back against box to compress weather seal and drill $5/16$ " holes in box wall at each factory hole in end cap.

B. Fasten with $3/8$ " x 1" self-threading bolts.

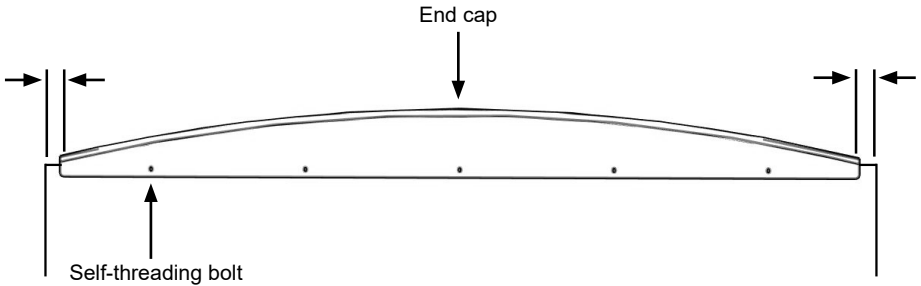

TOP MOUNT

A. Center and position end cap to overhang end of box by $1/4$ ". Mark deepest location at each hole on top of box.

B. Remove end cap and drill $5/16$ " holes at marked locations. Turn $3/8$ " x 1" self-threading bolts halfway in. Slide end cap slots under bolt heads. Ensure $1/4$ " overhang, press down to compress weather seal and finish tightening bolts.

Tip: If box has uneven layer of metal at top where end cap mounts, apply adhesive seal tape and shim with washers (not included with kit) under end cap at each bolt.

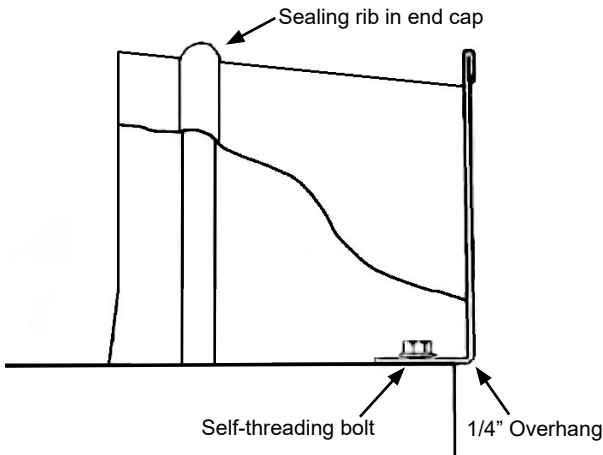

3: MOUNTING END CAP BRACKETS

Perform one of the following to mount end cap brackets or use included instructions if applicable:

NOTE: For stainless steel hardware, see page 2 for bolting procedures.

SIDE MOUNT

- Center end cap bracket underneath sealing rib of end cap and butt up against inside of box. Use bracket as template to mark center of (4) hole locations.
- Drill (2) 5/16" holes through box at marked locations and secure with 3/8" x 1" self-threading bolts.
- Drill (2) 3/8" holes through end cap at marked locations. Tilt inside edge of end cap up 1/4" and secure with 3/8" x 1" Allen button head bolts and nuts.
- Repeat Step 3A-C to install end cap bracket on opposite side.
- Repeat Steps 1-3 for remaining end cap.

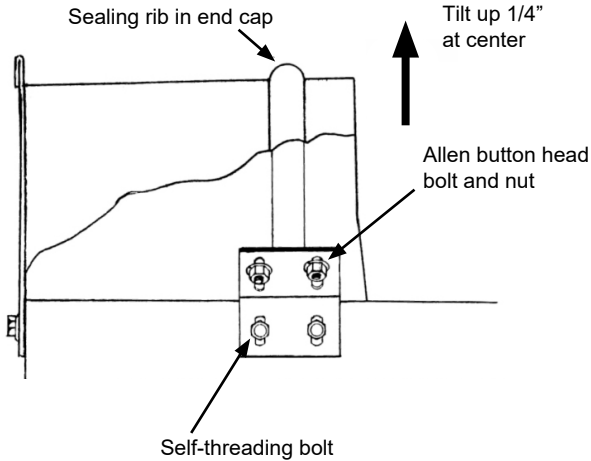

TOP BOLT THROUGH

- Tilt inside edge of end cap up 1/4" and drill 5/16" hole at etched mark on both sides of end cap.
- Use 3/8" x 1" self-threading bolt to cut threads. Secure with 3/8" x 1" Allen button head bolt.
- Repeat Steps 1-3 for remaining end cap.

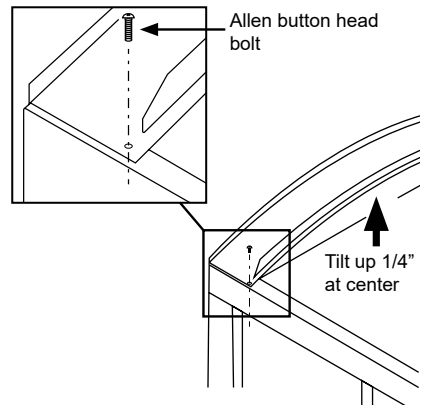

4: DETERMINING BOW PLACEMENT

NOTE: Supplied bows are not designed to hold box together. Leave all existing bows, braces and chains in place.

A. First and last bow should be placed 30" in from end cap face.

B. Divide space from first to last bow by number of bows left plus one to determine position of remaining bows.

IMPORTANT: All bows must be used.

* Example:

If - 2 bows are left,
divide by 3 for 3 equal spaces

If - 4 bows are left,
divide by 5 for 5 equal spaces

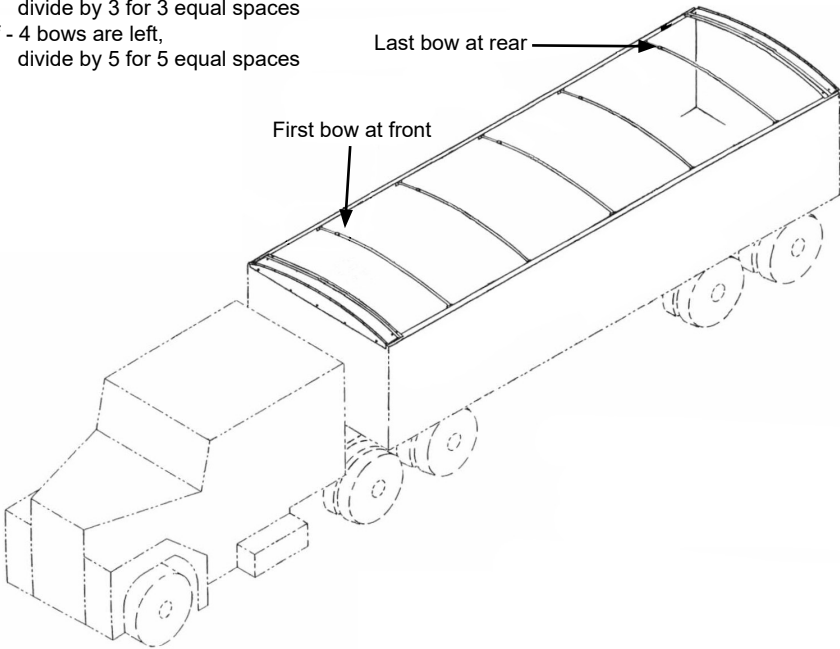

5: MOUNTING BOWS

Perform one of the following to mount bows:

NOTE: For stainless steel hardware, see page 2 for bolting procedures.

SIDE MOUNT

A. Attach bow pocket to inside of box, flush with top. Use pocket as template to drill (2) 5/16" holes and secure with 3/8" x 1" self-threading bolts.

B. Repeat for opposite side.

C. Slide bow extension into end of bow and place bow into bow pockets.

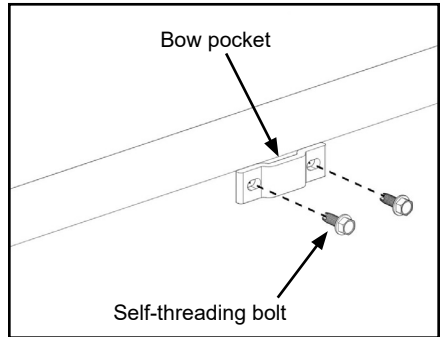

TOP MOUNT

A. Ensure 1/2" space from outside edge of box rail to bow. Drill 5/16" hole and use 3/8" x 1" self-threading bolt to cut threads. Secure with 3/8" x 1" Allen button head bolt.

B. Slide bow extension into end of bow.

C. Repeat Step 5A for opposite side.

NOTE: Deburr any sharp edges at bow ends.

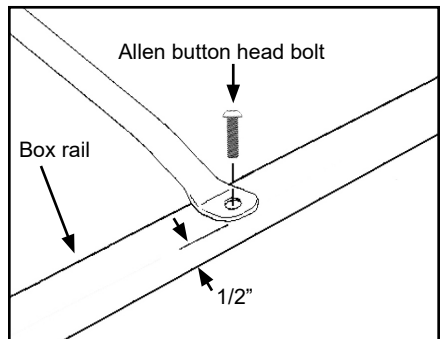

BOTH SIDE AND TOP MOUNT

D. Center first bow in an upright position and adjust to sit 1" higher than end cap.

Tip: Clamp locking pliers to hold in place.

E. Drill 5/16" hole 1" from end of bow through bow and into extension. Secure with 3/8" x 1" self-threading bolt.

IMPORTANT: Ensure bolt head does not rub on tarp.

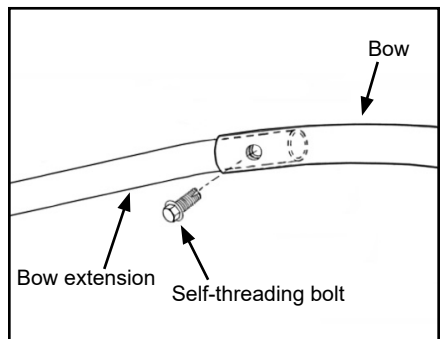

F. Repeat Step 5 for remaining bow locations.

Tip: Set front and rear bows to correct height. Install ridge strap and draw tight until no slack. Adjust remaining bows to touch bottom of ridge strap, ensure strap remains level.

5: MOUNTING BOWS (Continued)

HD ALUMINUM

A. Set bow pocket on top of inside edge of box rail. Use pocket as template to drill (4) 5/16" holes and secure with 3/8" x 1" self-threading bolts.

NOTE: Shim (not included with kit) behind bow pockets if necessary.

B. Repeat for opposite side.

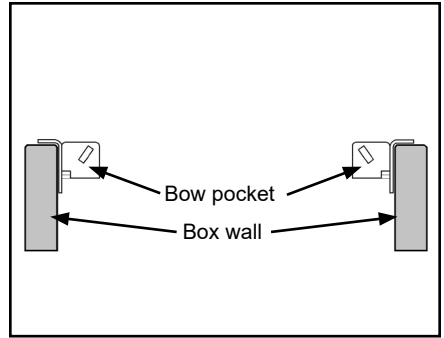

C. Place bow with factory drilled hole into bow pocket. Secure with carriage bolt and nylock flange nut, leaving finger tight.

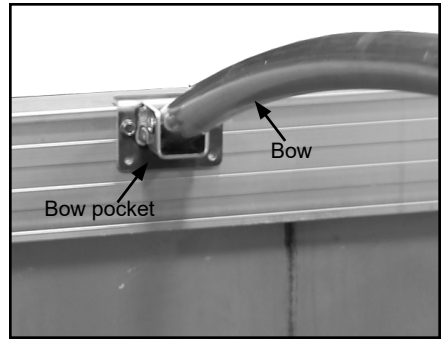

D. Place bow extension into opposite bow pocket. Secure with carriage bolt and nylock flange nut, leaving finger tight. Hold bow up to bow extension and make mark at bow extension collar on bow. Remove bow from bow pocket, then cut at mark.

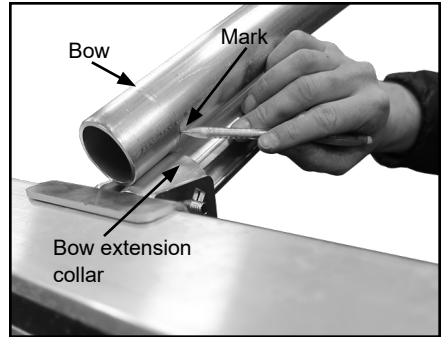

IMPORTANT: Make cut perpendicular to bow. Do not cut end of bow with factory drilled hole.

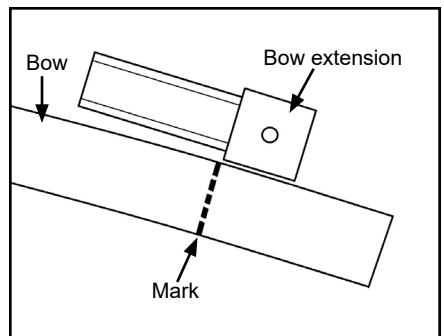

5: MOUNTING BOWS (Continued)

E. Slide bow extension into trimmed end of bow. Place bow into bow pockets and secure each end with $\frac{3}{8}$ " x 3" carriage bolt and nylock flange nut.

NOTE: Extension will sit loose within the bow.

F. Repeat Step 5 for remaining bow locations.

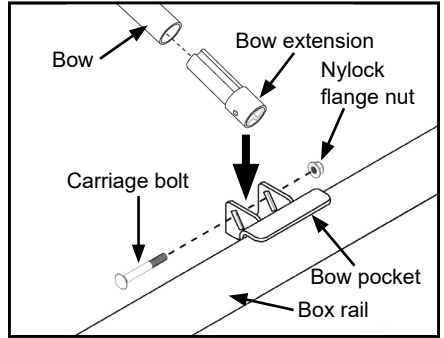

5: MOUNTING BOWS (Continued)

FLEXIBLE

A. Measure inside trailer box width and perform one of the following:

7" Rise - Cut bow 1-1/2" longer than inside measurement.

12" Rise - Cut bow 4" longer than inside measurement.

NOTE: Adjust bows as needed for desired height.

B. Clamp bow pocket flush with top of box, use pocket as a template to drill (4) 5/16" holes. Secure with 3/8" x 1" self-threading bolts.

C. Repeat for opposite side.

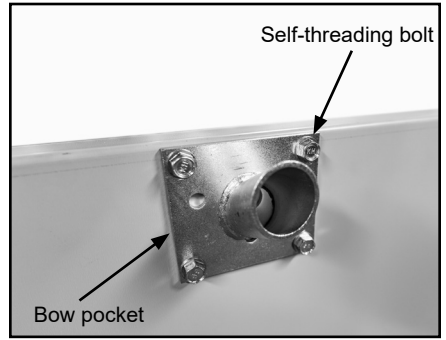
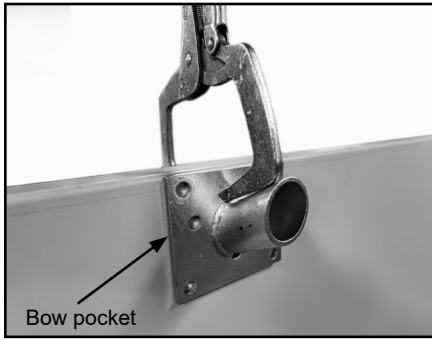

D. Insert flexible bow into bow pockets.

E. Repeat Step 5 for remaining bow locations.

IMPORTANT: Ensure bow is fully seated before continuing.

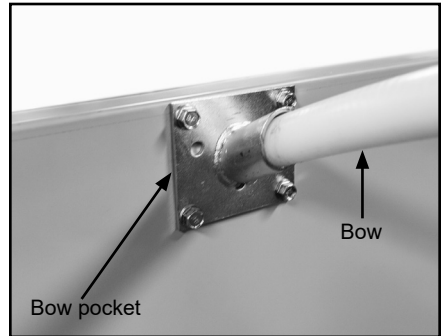

TIP: Loosening bow pocket hardware may ease bow insertion, then fully tighten hardware.

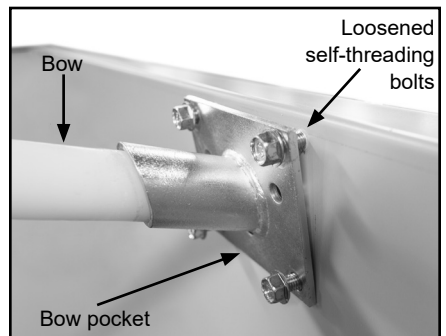

6: MOUNTING RIDGE SUPPORT

Perform one of the following to mount ridge support:

RIDGE STRAP

A. Attach hook end of strap to hole in center of front end cap. If installing (2) ridge straps, attach hooks to off centered holes.

B. Run strap over bows and attach ratchet end of strap to rear end cap. Thread strap through ratchet, then draw strap tight. **DO NOT OVER TIGHTEN**. Cut excess strap to 8" and fuse end with heat source.

Tip: Twisting ridge strap prior to attaching ratchet helps decrease commodity spatter. Number of twists depends on length of trailer, adjust accordingly. Ensure not to wind any twist in ratchet.

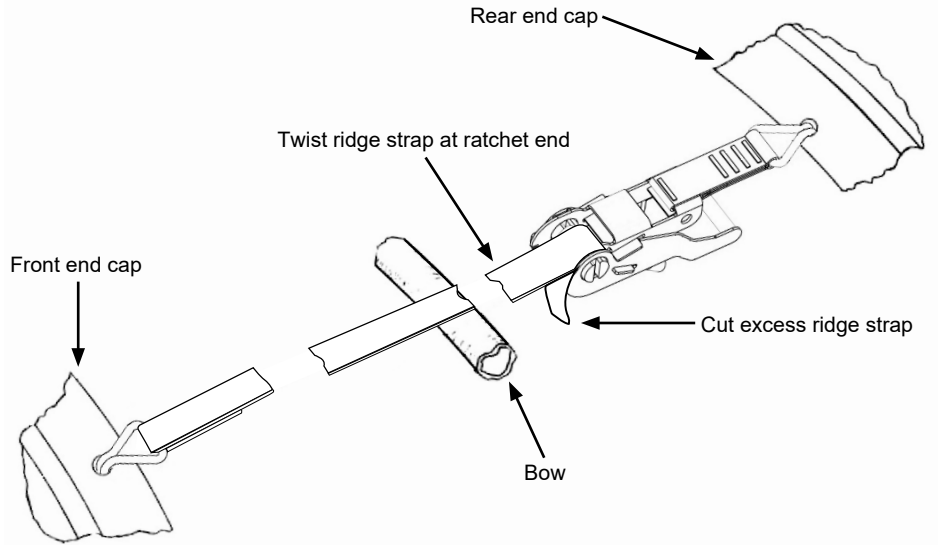

6: MOUNTING RIDGE SUPPORT (Continued)

RIDGE ROPE

A. Attach hook end of rope to hole in center of front end cap. If installing (2) ridge ropes, attach hooks to off centered holes.

B. Run rope over bows and attach ratchet end of rope to rear end cap. Thread rope through ratchet as shown, pull on loose end of rope to remove slack. Ratchet rope tight, at least 4 wraps. **DO NOT OVER TIGHTEN.** Cut excess rope to 8" and knot end.

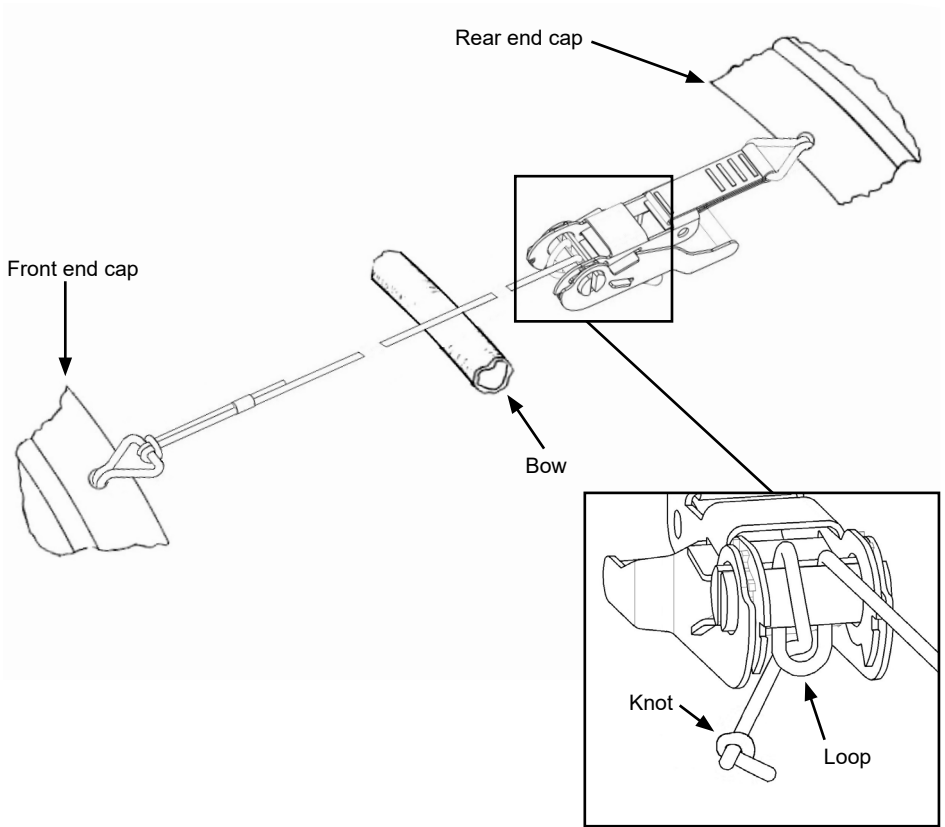

7: DETERMINING TARP STOP PLACEMENT

NOTE: Tarp stops secure stationary side of tarp to box.

- For normal roll applications, mount tarp stops on passenger side of box.
- For reverse roll applications, mount tarp stops on driver side of box.

A. Place front and rear tarp stops in line with sealing rib in end cap.

B. Divide space from front to rear tarp stop by number of tarp stops left plus one to determine position of remaining tarp stops.

*Example:

If - 2 tarp stops are left,
divide by 3 for 3 equal spaces

If - 4 tarp stops are left,
divide by 5 for 5 equal spaces

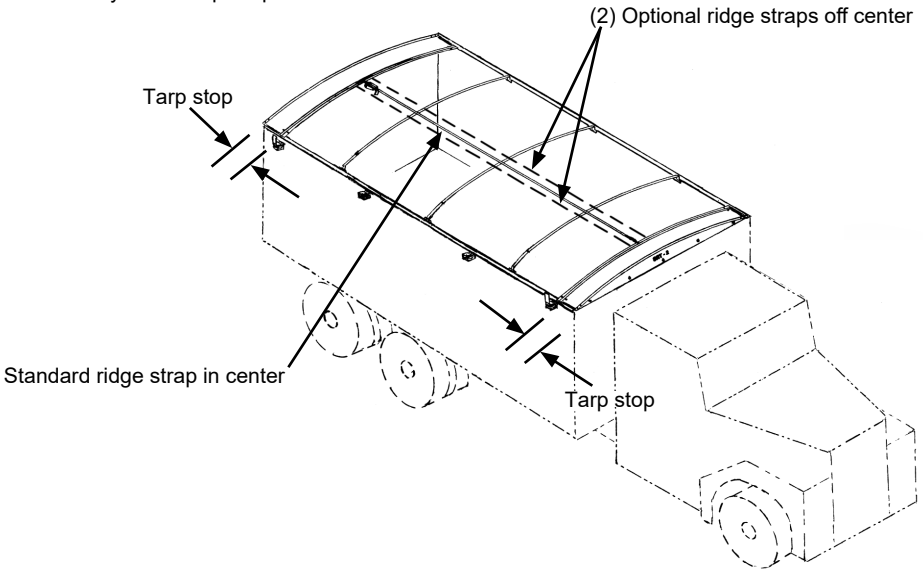

8: MOUNTING TARP STOPS

NOTE: For stainless steel hardware, see page 2 for bolting procedures.

A. If using optional tarp stop spacer bracket, use bracket as template to drill (4) 5/16" holes and secure with (2) 3/8" x 1" bolts, lock washers and nuts and (2) 3/8" x 1-1/4" Allen button head bolts, lock washers and nuts.

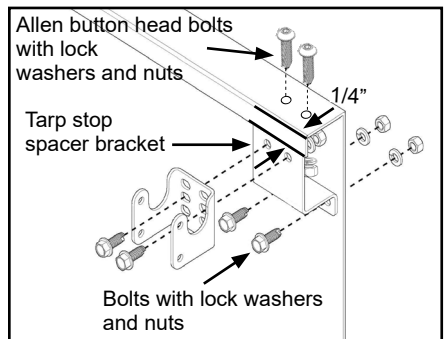

8: MOUNTING TARP STOPS (Continued)

B. Place front and rear base brackets 1/4" down from top of box and drill (4) 5/16" holes and secure with 3/8" x 1" self-threading bolts.

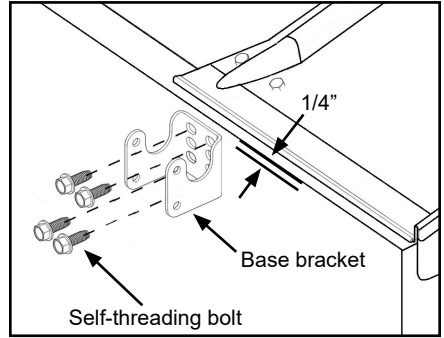

C. Place remaining base brackets 1/4" down from top of box, drill (2) 5/16" holes and secure with 3/8" x 1" self-threading bolts.

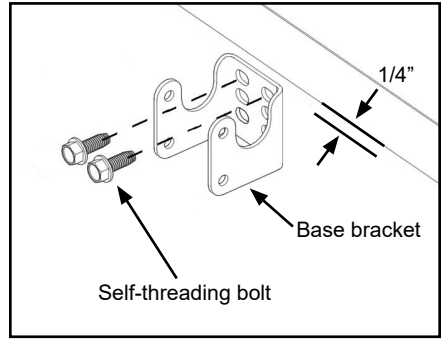

D. Align lower hole in upright with lower hole in base bracket. Assemble with clevis pin and bow-tie pins. Leave tarp stop in open position for now.

E. Repeat Step 8D for remaining tarp stops.

NOTE: Install uprights with set screw at front and rear.

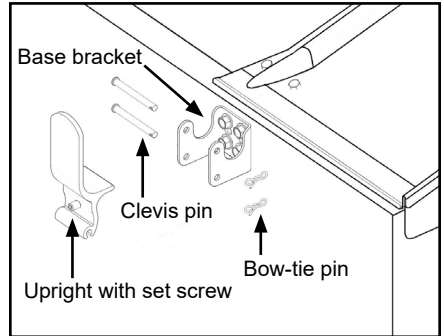

9: INSTALLING ROLL TUBE SPLICE

NOTE: This step is for kits with multiple roll tube sections.

Perform one of the following to install roll tube splice:

WELDING ROLL TUBE

NOTE: Ensure rope channels are aligned.

A. Insert half of roll tube splice into end of first roll tube.

B. Secure roll tube splice by plugging each of the (4) roll tube holes with aluminum welds.

C. Insert second roll tube onto opposite end of roll tube splice until tubes are tight against each other.

D. Secure second roll tube by plugging each of the (4) roll tube holes with aluminum welds.

E. Let all welds cool and grind flush to prevent tarp wear.

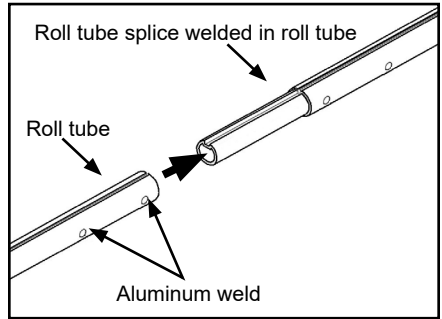
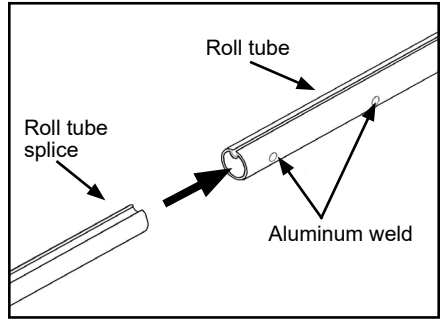

ALTERNATIVE TO WELDING

NOTE: Ensure rope channels are aligned.

A. Insert half of roll tube splice into end of first roll tube.

B. Drill (4) pilot holes into roll tube splice through center of roll tube holes using 1/8" bit.

IMPORTANT: Pilot holes must be centered in holes on roll tube.

C. Secure roll tube splice by turning 1/4" x 3/4" self-drilling Phillips screws into pilot holes.

D. Insert second roll tube onto opposite end of roll tube splice until tubes are tight against each other.

E. Drill (4) pilot holes into roll tube splice through center of roll tube holes using 1/8" bit.

F. Secure roll tube splice by turning 1/4" x 3/4" self-drilling Phillips screws into pilot holes.

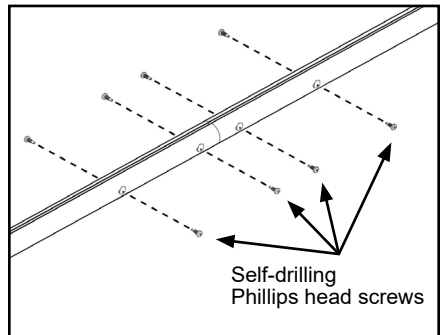
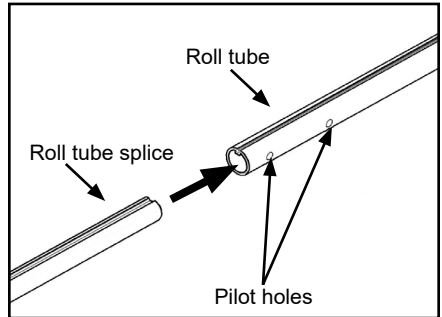

10: PREPARING STATIONARY TUBE

NOTE: This step is for kits with multiple stationary tube sections.

A. Insert swedged end of stationary tube into standard end.

IMPORTANT: Before drilling, align tarp rivet holes with each other.

B. Drill $7/32$ " hole through two layers of tube wall. Insert drive rivet into hole. Ensure rivet is fully seated and set with hammer.

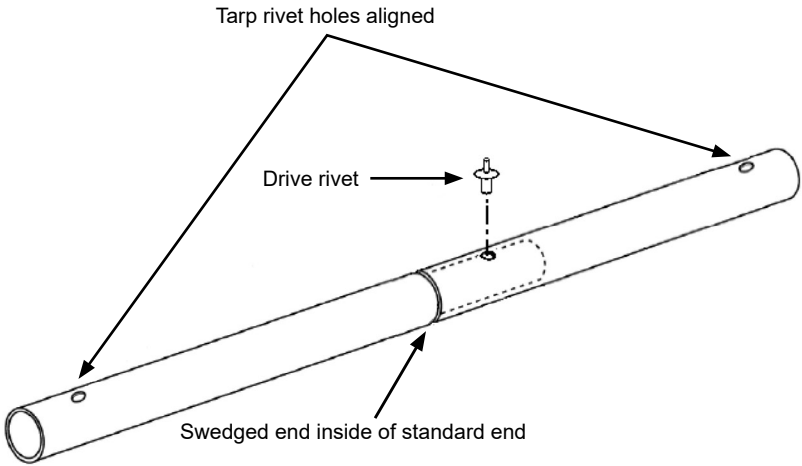

11: ATTACHING ROLL TUBE TO TARP

A. On a clean floor, lay tarp out flat with rope in large pocket facing down and exterior side facing up (raw edge of hems and pockets are down).

NOTE: Ensure holes in large pocket and roll tube are on same side of rope.

B. Align channel on roll tube with rope.

C. Slide black end of roll tube onto rope and into large pocket.

IMPORTANT: Ensure rope is fully engaged in rope channel on roll tube.

D. Align holes in tarp and roll tube, then insert drive rivet. Ensure it is fully seated and set with hammer.

Tip: Liner tool helps align tarp and roll tube holes to fully seat rivet.

E. On other end, pull tarp by hand to align holes in tarp and roll tube, then insert drive rivet. Ensure it is fully seated and set with hammer.

NOTE: Tarp is designed to be stretched to minimize wrinkling.

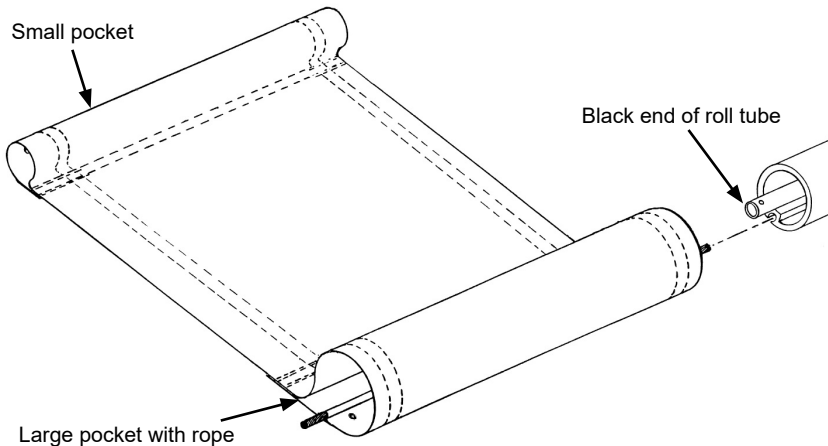

12: ATTACHING STATIONARY TUBE TO TARP

- A. Tap end plug into each end of stationary tube.
- B. Slide stationary tube into small pocket.
- C. Align holes in tarp and stationary tube, then insert drive rivet. Ensure it is fully seated and set with hammer.
- D. At other end, pull tarp by hand to align holes in tarp and stationary tube, then insert drive rivet. Ensure it is fully seated and set with hammer.

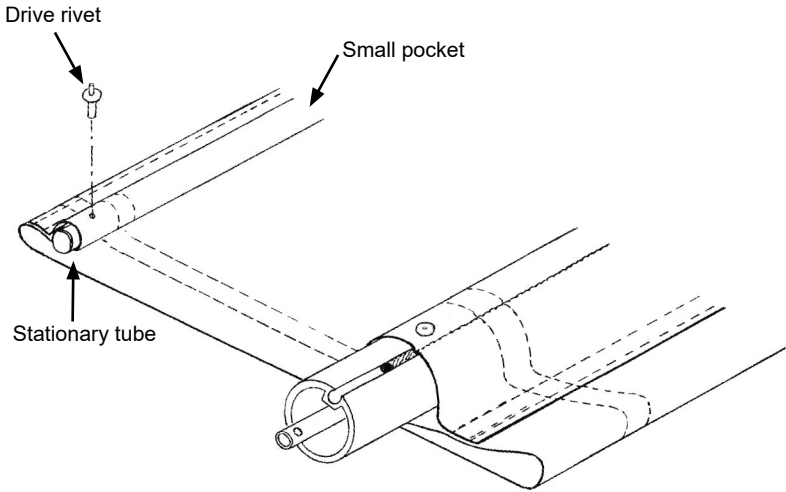

13: ATTACHING SPOOLS

NOTE: Spool marked R (right) use with red marked spring and cartridge.

IMPORTANT: Do not use grease or lubricant on spools or tube.

A. Slide spool onto end of roll tube according to (L) or (R) marking.

- For left spool (L), turn spool counterclockwise about 1" while pushing until spring engages in roll tube and spring tab engages hole in spool.
- For right spool (R), turn spool clockwise about 1" while pushing until spring engages in roll tube and spring tab engages hole in spool.

B. On non-drive side, slide PVC spacer on cartridge and secure with clevis and cotter pins, then bend cotter pin tabs.

NOTE: Non-drive side is opposite of tarp motor or crank handle.

C. On drive side, slide PVC spacer on cartridge, then insert clevis and cotter pins. Do not bend cotter pin tabs.

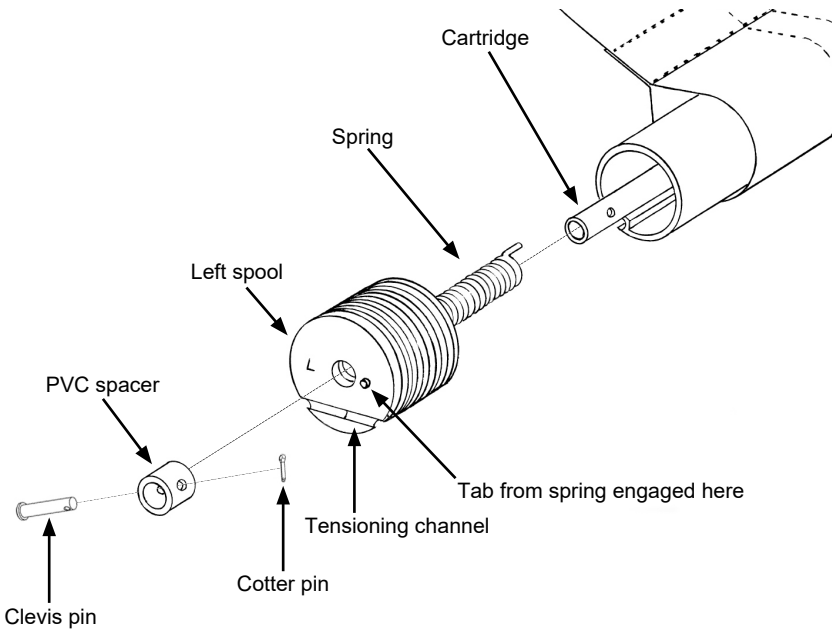

14: INSTALLING TARP ASSEMBLY

- A. Roll tarp assembly by hand to open position, roll tube to stationary tube.
- B. Place stationary tube into base brackets.
- C. Center assembly from front to rear of box. Be careful not to let tarp roll off box.

- For normal roll applications, red end goes to the rear, black end to the front.
- For reverse roll applications, black end goes to the rear, red end to the front.

D. Swing upright up and secure with clevis and bow-tie pins.

E. Repeat Step 14D for all tarp stops.

F. Tighten fasteners at front and rear tarp stops.

IMPORTANT: Fasteners prevent tube and tarp from sliding.

NOTE: If installing rubber uprights, drill 5/16" hole through rubber in line with stationary tube at front and rear. Secure with 3/8" x 1-1/4" self-threading bolt.

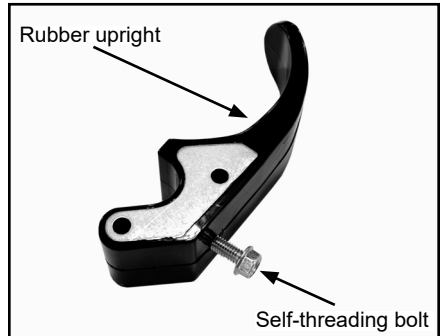
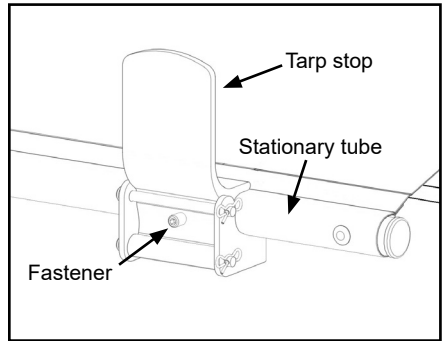
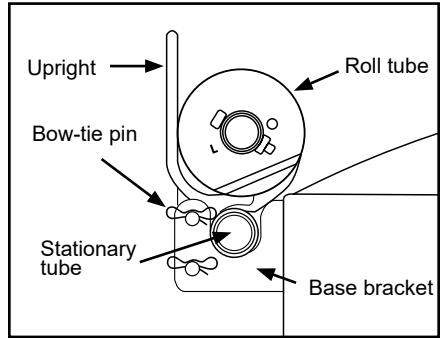

15: INSTALLING CABLES & RATCHETS

NOTE: For stainless steel hardware, see page 2 for bolting procedures.

- A. Unroll tarp by hand to other side of box and let tarp hang down. Ensure tarp is still centered from front to back of box and make adjustments as needed.
- B. Attach barrel end of cable to barrel groove on spool. Ensure cable follows grooves.
- C. Wrap cable around spool grooves up to last full wrap with cable next to box wall, attach ball end of cable to hook on ratchet strap.
- D. Pull down on ratchet while activating the release to extend ratchet to mark on strap, around 10-1/2" down. Mark (2) bolt locations on side of box.

NOTE: If ratchet cannot mount at this height, lower it slightly to the closest point for mounting.

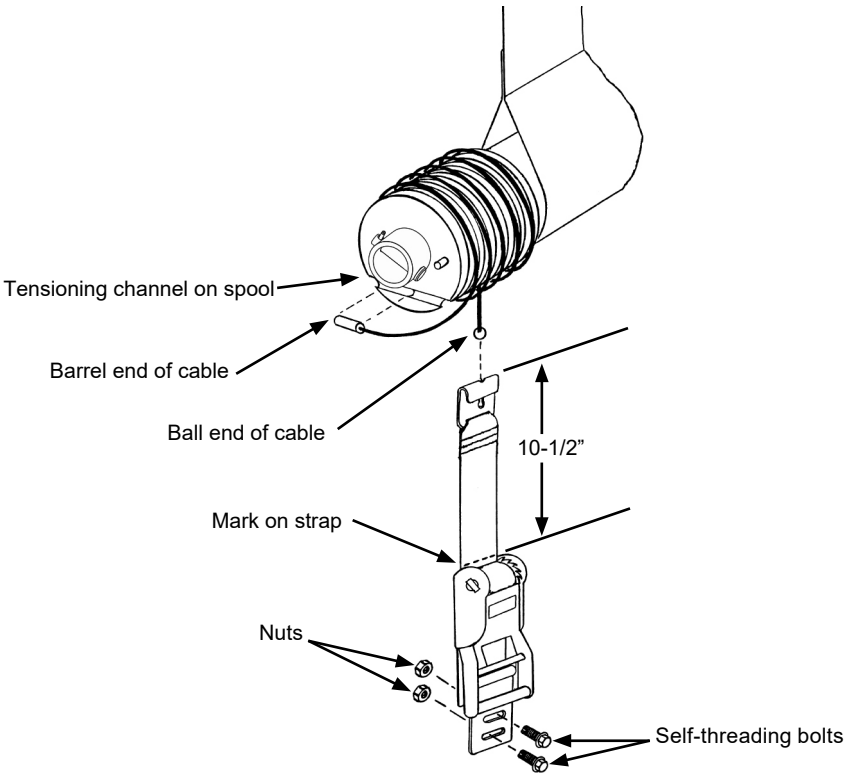

15: INSTALLING CABLES & RATCHETS (Continued)

E. Drill 5/16" holes at marked locations and secure with 3/8" x 1" self-threading bolts, when possible use nuts on inside of box. Ratchet must be securely mounted to side of box.

NOTE: If side walls of box are not strong enough to hold ratchet, make alterations or reinforcements as needed.

Tip: Use diverter if unable to find appropriate placement for ratchet (sold separately).

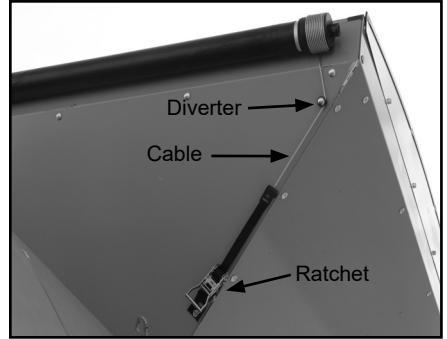

F. Repeat Step 15A-E to install cable and ratchet at opposite end of box.

G. Adjust ratchets to hold cables at angle, approximately 1 to 2 degrees off-center, then tighten ratchet bracket nuts. This ensures cables follow grooves on spools when operating tarp.

IMPORTANT: To prevent scratching or gouging, temporarily insert cardboard between box and ratchet hooks.

H. Locate and clean a suitable location to apply ratchet decal.



16: CABLE TENSION

A. As tension is applied with ratchet, the spool will turn. Proper tension is achieved when the tension channel is level at bottom.

Tip: Tighten ratchet an additional two clicks past level. Open and close tarp system approximately 5 times to pull tarp snug. Tension channel should be level at bottom. Install crank handle or motor prior to opening and closing tarp system.

IMPORTANT: Periodically check tension level and always keep ratchet handle in locked down position during use.

NOTE: Remove cardboard once tension is set.

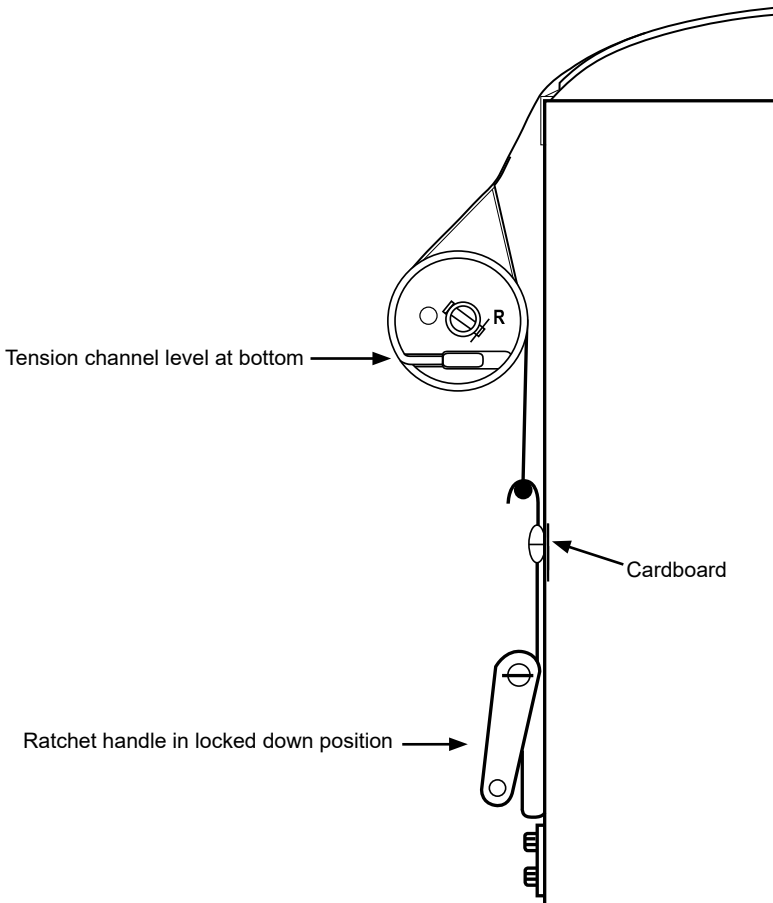

16: CABLE TENSION (Continued)

NOTE: After tensioning spool to horizontal position and tarp has been cycled, if cable has excessive slack, tighten ratchet to apply additional tension up to 25° and cycle again. Repeat as needed.

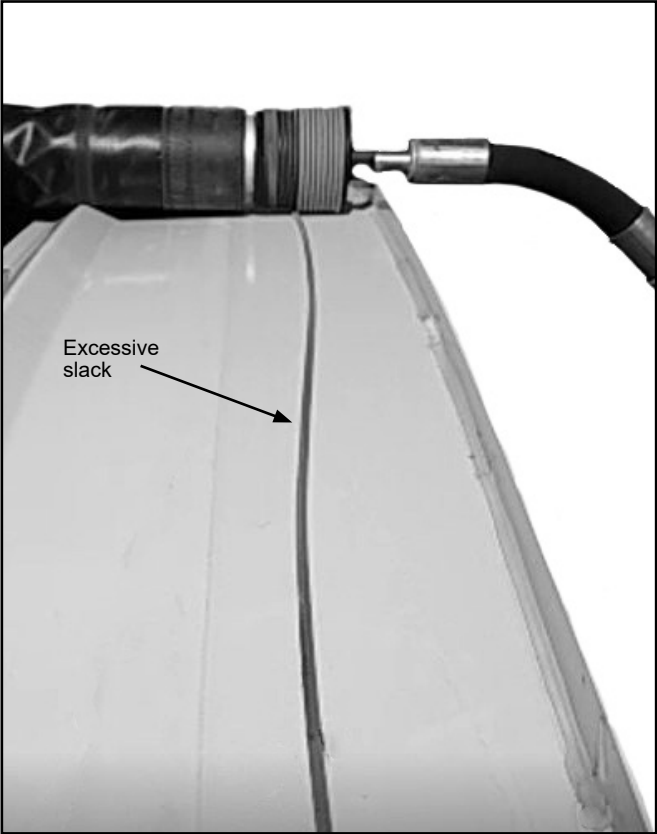

17: INSTALLING CRANK HANDLE ASSEMBLY

Refer to included electric conversion instructions if applicable.

A. Remove clevis and cotter pins securing PVC spacer at rear of box.

B. Slide handle through PVC spacer and into cartridge protruding from spool.

C. Align holes in handle, PVC spacer and cartridge then secure with clevis and cotter pins. Bend cotter pin tabs.

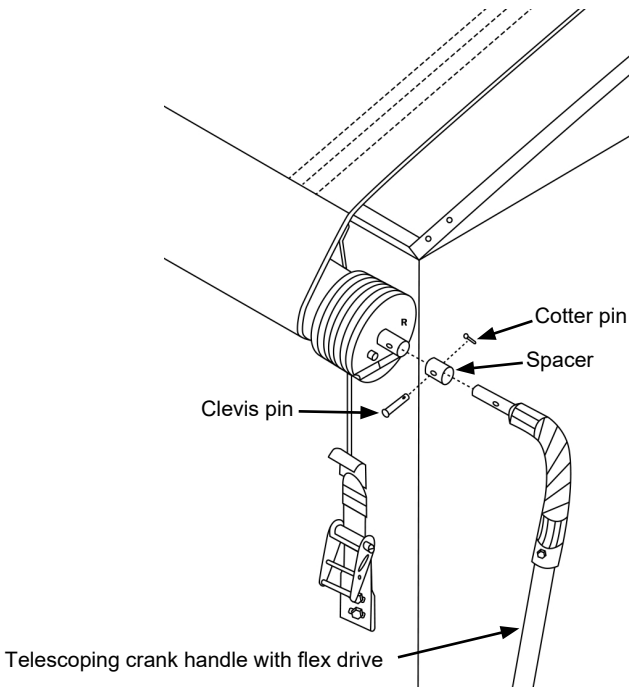

18: MOUNTING HANDLE HOLDER

Perform one of the following to mount handle holder:

NOTE: For stainless steel hardware, see page 2 for bolting procedures.

HANDLE HOLDERS

NOTE: In most cases, handle holders are installed as low as possible in rear corner of side walls on box.

- A. With tarp in closed position, snap handle holder onto crank handle and select best location on side wall. Mark hole.
- B. Roll tarp to open position and select best location on adjacent side wall. Mark hole.
- C. Drill (2) 5/16" holes at marked locations and secure handle holder with 3/8" x 1" self-threading bolts with threadlock adhesive.
- D. Locate and clean suitable positions to apply caution and important stickers.

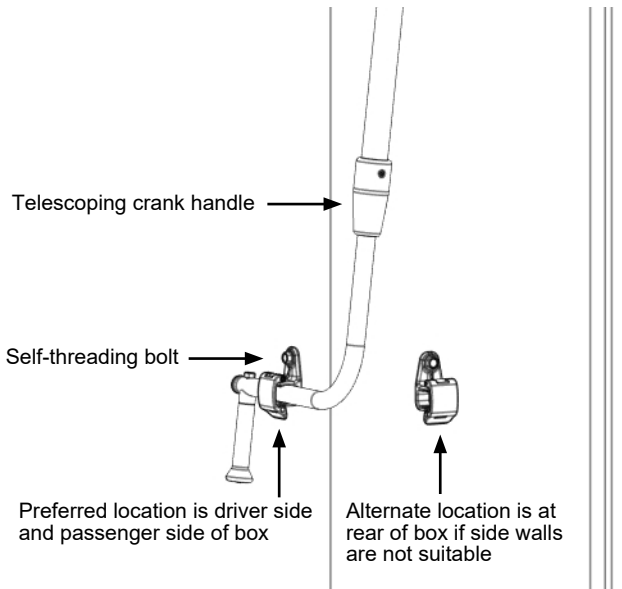

18: MOUNTING HANDLE HOLDER (Continued)

HANDLE HOLDER WITH STANDOFF

For Grain Carts refer to included handle holder extension instructions.

A. Crank roll tube to be in closed position with tarp tight, then lower handle to a vertical position and lift toward center of box to mark your choice of location for handle holder.

B. Use standoff as template to mark and drill (2) 5/16" holes into box then secure with 3/8" x 1" hex bolts, flat washers, lock washers and nuts.

C. Attach handle holder to standoff using 3/8" x 1" bolt and flat washer.

D. Locate and clean suitable positions to apply caution and important stickers.

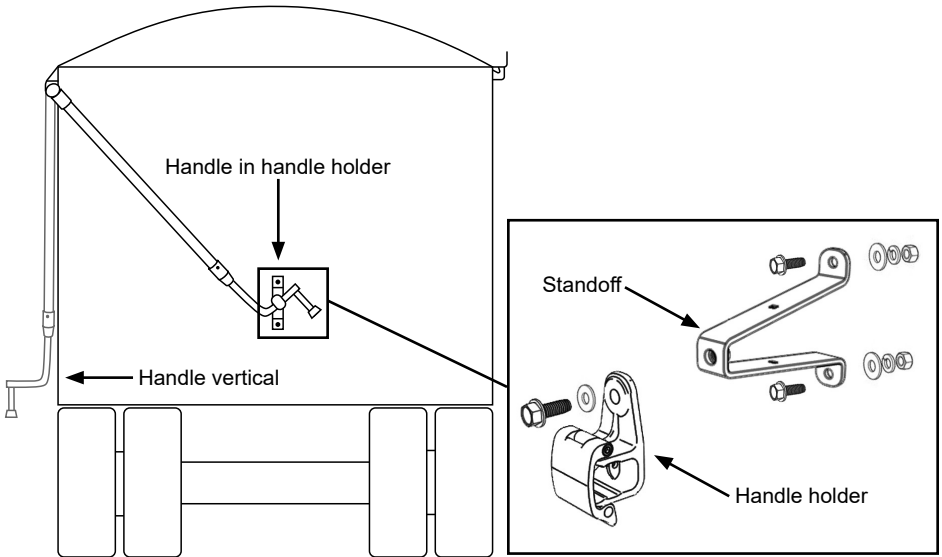

TROUBLESHOOTING

Cables do not stay in grooves on nylon spools when operating.

Tarp doesn't wind smooth. Binds on one end or both ends.

Cannot fully open tarp. (On boxes wider than 11' 6" it is normal for tarp to stop 6" to 8" from edge of box.)

Tarp sags in middle area.

Holes or tears in tarp.

Cable ratchets may need offset adjustment.

Check level of tension channels for proper tension.

Fasteners may be loose allowing tarp to "slip or walk." Recenter tarp between end caps. Tighten fasteners.

Spools may be binding on roll tube, clean and reinstall.

Cable tension may be too loose. Check level of tension channels for proper tension.

Tarp has been altered or improperly repaired.

Bows may be spaced too far apart, bent, or adjusted too low. Self-threading bolt that secures bow height adjustment may be missing.

Missing or loose ridge strap.

Cable tension may be too loose. Check level of tension channels for proper tension.

Contact your local Agri-Cover dealer for replacement tarp or tarp repair kit.

When new tarp or parts are needed replace with original Agri-Cover parts.

OPERATION

TO CLOSE

- A. Use both hands to remove crank handle from holder. Extend crank handle to a comfortable operating position.
- B. Roll tarp to completely closed position.
- C. Push crank handle into holder and close.

TO OPEN

- A. Use both hands to remove crank handle from holder. Extend crank handle to a comfortable operating position.
- B. Roll tarp to completely open position.

NOTE: Completely open is when tarp roll touches tarp stops. Attempting to roll tarp past open position could cause damage to tarp stops, tubes and tarp.

- C. Push crank handle into holder and close.

INSPECTION AND MAINTENANCE

Periodic preventive maintenance should be practiced:

- Inspect tarp and hardware for abrasions or loosened bolts that may need adjustment. Adjust tension when needed. Tarp must be kept to a recommended tension setting equally on both ends, or excessive tarp wear may occur.
- Tarp should always operate as well as when first installed. Make all appropriate repairs or adjustments immediately before serious damage occurs.
- Check the tightness of mounting bolts and electrical connections, remove any dirt or corrosion that may have accumulated on the electrical connections.
- Always use genuine Agri-Cover, Inc. replacement parts, use serial number to easily order replacement tarp.

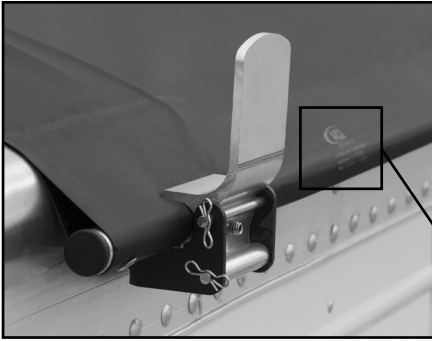

Serial number is located at rear of tarp on stationary tube side

For Replacement: 1-800-233-4655
EZL/ATL Part #: KA-116132A010
SERIAL: 123456789 18.12.2015

MANUFACTURER'S LIMITED WARRANTY

Agri-Cover, Inc. extends the following Limited Warranty on its SRT-2® Spool Roll Tarp:

Agri-Cover, Inc. warrants its SRT-2® Spool Roll Tarp to be free from defects in material and workmanship under normal use for one (1) year from date of manufacture unless accompanied by proof of purchase. This Limited Warranty does not cover any failure due to abuse, misuse, alteration, neglect, improper assembly or installation, or improper maintenance.

ANY IMPLIED WARRANTY APPLICABLE TO THE SRT-2® SPOOL ROLL TARP IS LIMITED IN DURATION TO ONE YEAR FROM THE DATE OF MANUFACTURE UNLESS ACCOMPANIED BY PROOF OF PURCHASE. Agri-Cover Inc.'s sole obligation under this Limited Warranty or any implied warranty is limited to the repair or replacement at its option, of defective parts only. No labor or service allowance is given or implied. IN NO EVENT SHALL AGRI-COVER, INC. BE LIABLE FOR INCIDENTAL, CONSEQUENTIAL, OR SPECIAL DAMAGES. EXPRESSLY DISCLAIMS ANY AND ALL IMPLIED WARRANTIES OF MERCHANTABILITY, AND THERE ARE NO WARRANTIES WHICH EXTEND BEYOND THE LIMITED WARRANTY DESCRIPTION CONTAINED HEREIN.

For warranty, have serial number ready and fill out the warranty claim form at agricover.com/warrantyclaim or call Customer Service Department at 800-233-4655 to determine if only a replacement part is needed or if the tarp needs to be returned for inspection and repair. Goods to be returned must have a pre-authorized RA # (Return Authorization Number) – obtained by calling the number above. Mark the number on the package and ship it freight prepaid to address below. Agri-Cover will pay freight to return goods to sender.

This Limited Warranty gives you specific legal rights and you may have other rights, which vary, from state to state.

For replacement parts shop at agricoverparts.com or call Customer Service at 800-233-4655.



Agri-Cover, Inc.
Customer Service Dept
3000 Hwy 281 SE
Jamestown, ND 58401
Phone: 800-233-4655

Hours: 8:00 am - 5:00 pm CST Monday through Friday, except Holidays