



AGRI-COVER™ REMOTE CONTROL INSTRUCTIONS

Use these instructions to install and operate remote control with AGRI-COVER™ Control Box. Read and follow these instructions along with the installation instructions carefully before using the Control Box.

NOTICE TO INSTALLER: Even if familiar with product, read instructions prior to installation as improvements may be made without notice. Always handle components with care. If you have questions or problems, have serial number ready and call customer service. When done, these instructions must be given to the consumer.

NOTICE TO CONSUMER: Before using AGRI-COVER™ Control Box and Remote Control, read operating and safety sections. Save these instructions for future reference.

FOR YOUR RECORDS

DATE PURCHASED: _____
WHERE PURCHASED: _____
SERIAL NUMBER 1: _____
(Located inside Control Box cover)
SERIAL NUMBER 2: _____
(Located on back of Remote Control)



Questions? 800-233-4655
agricover.com

PREPARATION

Unpack AGRI-COVER™ Remote Control.

NOTE: Hardware appearance and components may vary.

TOOLS NEEDED

- Slotted screwdriver
- #2 Phillips screwdriver
- Protective eyewear

SAFETY INFORMATION

Do not install or use this product without reading and understanding these instructions. Only allow people who know and understand the safety rules to use this system.

- Always use caution when operating tarp.
- Disconnect power before servicing system or electrical components.
- Ensure tarp is fully open before unloading or loading.
- Ensure people are clear of tarp system before and during operation.
- Do not operate tarp with box hoisted in elevated position.
- If tarp is covered with snow or debris, remove before operating.
- End caps must be free from commodity that may be piled on them. Commodity should not be piled higher than end caps.
- Ensure tarp system is fully open or fully closed before operating vehicle at highway speeds.
- Instruct everyone who will operate this tarp on the proper procedures.
- Do not directly spray the electric motor and electrical connections with a pressure washer.
- Never allow children to operate or play with system.
- Only operate system when tarp is completely visible.

REMOTE CONTROL SPECIFICATIONS

SPECIFICATION	DESCRIPTION
Battery	9V
Battery Life	50 hours
Channels	99
Display	2 digits
Operating frequency	340 MHz band
Operating range	100 feet

REMOTE CONTROL DIAGRAM

The following diagram identifies the remote control components.

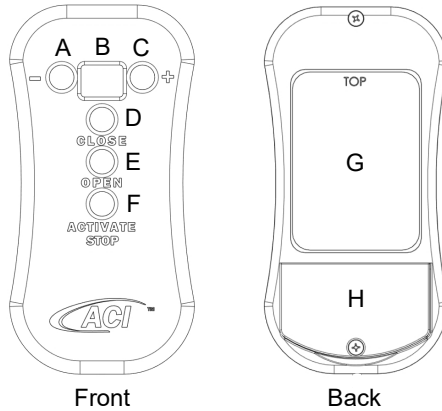

ID	COMPONENT	DESCRIPTION
A	- (Channel Decrease)	Decreases channel number. Press button to decrease once or hold button to decrease rapidly.
B	Display	Displays selected channel.
C	+ (Channel Increase)	Increases channel number. Press button to increase once or hold button to increase rapidly.
D	Close	Closes tarp. Depending on mode, either: press and hold or press once.
E	Open	Opens tarp. Depending on mode, either: press and hold or press once. Also, used during remote control programming process.
F	Activate/Stop	Stops opening or closing tarp. Also, if inactive for three minutes, press button for 3 seconds to turn on remote control's communication hardware.
G	Label/Serial Number	Provides brief instructions, a short channel list and serial number.
H	Battery door	Provides access to 9V battery.

OVERVIEW

After Control Box is installed, remote control may be set up. Remote control provides wireless push-button control. Remote control is simple to use and provides convenient, reliable operation and is suitable for a wide variety of applications.

NOTE: Only control boxes with rotary switches are compatible with wireless remote controls.

1. SET WIRELESS OPERATING MODE

A rotary switch inside Control Box configures operating mode (how remote control and Control Box operate tarp).

▲ CAUTION: Setting operating mode requires turning a rotary switch inside Control Box near power wires. Avoid touching power wires.

A. Open Control Box and locate rotary switch. Turn arrow on switch to desired setting:

Switch setting 4 (latching mode): On remote control or at switch on Control Box, **Pressing and releasing** Open or Close causes tarp to fully open or close automatically.

Switch setting 7 (momentary mode): On remote control or at switch on Control Box, **Pressing and holding** Open or Close causes tarp to open or close.

NOTE: The switch's arrow indicates which switch position is enabled.

B. Disconnect power cables from battery.

C. Reconnect power cables to battery.

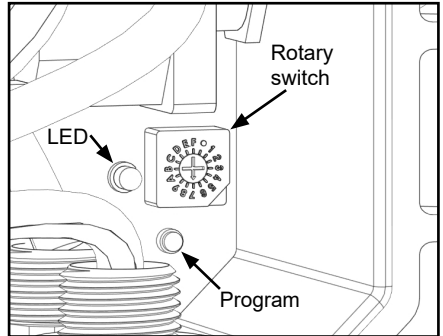
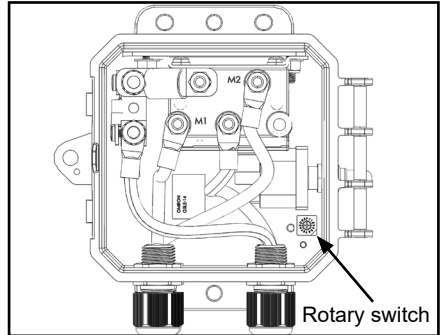

2. PROGRAM A REMOTE CONTROL

Your Control Box and remote control come pre-programmed to each other. If reprogramming is required or you desire to use a different channel, follow procedures below.

CLEAR CONTROL BOX

▲ CAUTION: This step involves pressing a button near power cables. Avoid touching power wires.

A. Open Control Box and locate Program button.

B. Press and hold Program button, LED activates. Release Program button.

C. Within 5 seconds, press and hold Program again, LED flashes.

D. Continue to hold Program, LED flashes faster.

E. LED extinguishes when Control Box is cleared. Release Program button.

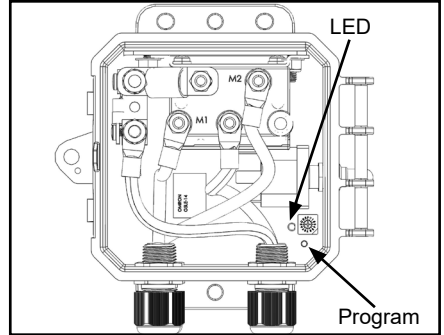

2. PROGRAM A REMOTE CONTROL (Continued)

PROGRAM REMOTE TO CONTROL BOX

A. Use + and - to select desired remote channel.

NOTE: There are 99 selectable channels.

B. Open Control Box and locate Program button.

C. In Control Box, press and hold Program, LED activates. Release Program button.

D. Within 5 seconds press and hold Open on remote control. LED flashes once when remote button is initially pressed.

E. On remote control, continue to hold Open, LED in Control Box flashes.

F. In Control Box, LED extinguishes when Control Box is programmed, release Open button.

G. On remote control, press and hold Activate/Stop for three seconds to activate communication hardware and connect to Control Box.

H. Test operation.

I. Repeat Steps A through H to program an additional remote to Control Box or program same remote to a different Control Box with a new channel.

IMPORTANT: After Control Box and remote control are configured, lockout Control Box with user supplied lock, included cable tie or Phillips screw (if equipped).

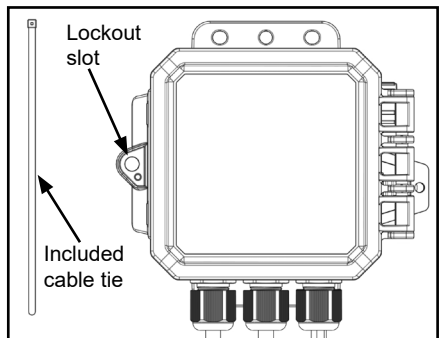
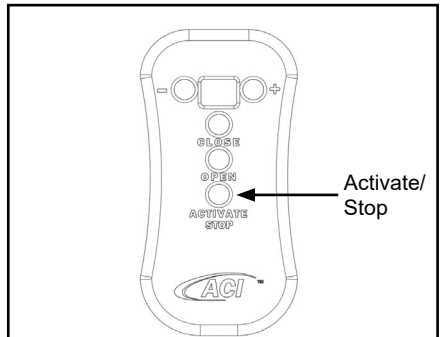
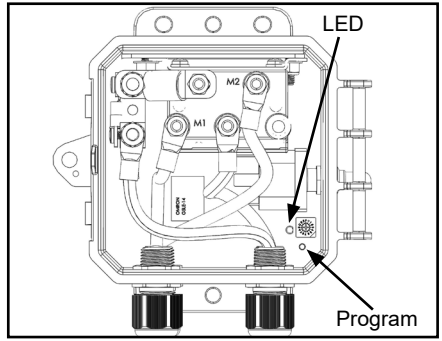
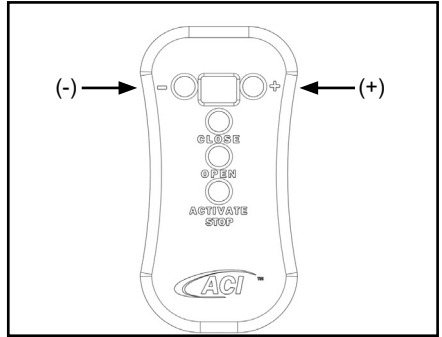

3. CONNECTING REMOTE TO CONTROL BOX

NOTE: After 3 minutes of inactivity, remote control times out and deactivates its communication hardware.

A. To activate remote control communication hardware and connect to Control Box, press Activate/Stop for approximately 3 seconds. Display will show selected channel.

NOTE: If display alternately flashes, Control Box is still active to that channel. Flashes will stop if channel is changed. Existing channel is active for 3 minutes.

NOTE: LED inside Control Box illuminates when remote control is connected.

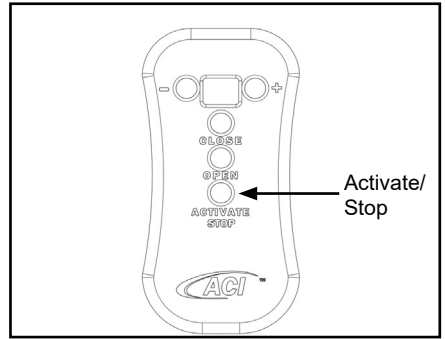

4. OPERATING INSTRUCTIONS

There are two methods for opening and closing tarp with remote. Method depends on which operating mode is configured.

A. Press + or - to choose desired channel.

NOTE: If inactive for 3 minutes, connect remote to Control Box as described in Step 3.

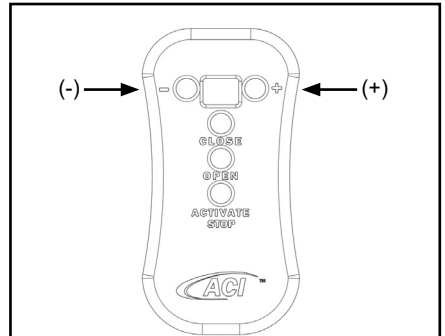

B. Depending on operating mode, perform one of the following:

Latching mode (switch setting 4): Press and release Open to automatically roll tarp fully open. Press and release Close to automatically roll tarp closed.

To STOP automatic cycling, perform one of the following:

- On Control Box, press toggle switch.
- On remote, press Stop, Open or Close.

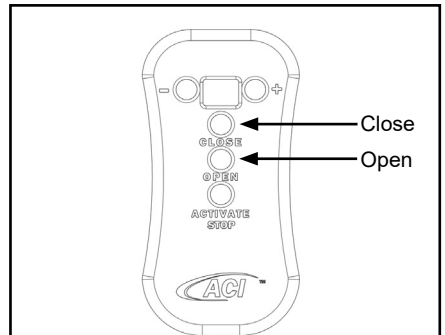

Momentary mode (switch setting 7): Press and hold Open to roll tarp fully open. Press and hold Close to roll tarp closed.

NOTE: If motor controller senses a fault 2 times consecutively in same direction, tarp direction must be reversed before trying again.

5. REMOTE BATTERY REPLACEMENT

NOTE: If "Lb" (low battery) appears on remote display or remote becomes unresponsive, replace battery.

A. Use Phillips screwdriver to remove screw in bottom of battery door.

B. Remove battery door.

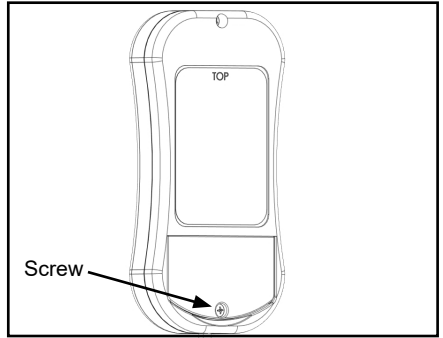

C. Remove battery.

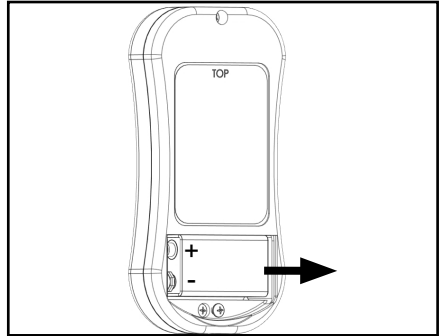

D. Insert new 9V battery.

NOTE: Ensure battery polarity matches the wire terminals.

E. Reinstall battery door and screw.

NOTE: Remote may need to be reprogrammed after battery is changed.

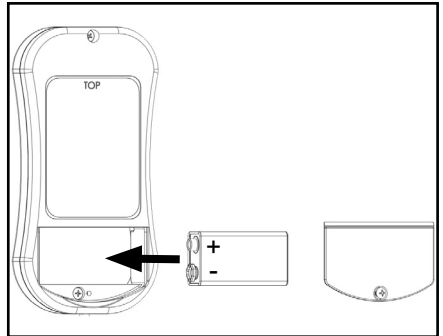

GENERAL TROUBLESHOOTING

If system has a battery cutoff switch, ensure it is turned to "ON" position.

Check all wiring components.

A. Check positive (+) and negative (-) wire connections on vehicle battery.

B. Retighten and re-crimp loose connections.

C. Replace any corroded connections.

D. Check all wires for worn or bare spots.

E. Verify 12 volts or more come into Control Box while system is operating.

Check power sources.

A. Check vehicle battery and charge, replace if required.

Check for physical damage to any equipment.

A. Repair or replace if required.

TROUBLESHOOTING REMOTE CONTROL

PROBLEM

SOLUTION

Remote transmitter does not work. None of the lights turn on when remote is turned on.

A. Check remote for dead battery. If battery is dead, replace with new, quality, high capacity battery. Ensure battery is loaded correctly in remote and terminals are clean. If replacing battery does not work, problem may be in remote.

Remote does not work, battery is good and lights are working. System operates with toggle switch but not with remote. Remote not communicating with Control Box.

A. Hold Activate/Stop for three seconds to activate the remote control and connect to Control Box. Ensure remote is set to correct channel and try again. If no change, reprogramming is needed (see Step 1 on page 4).

B. Ensure to be within several feet of Control Box and try again. If remote transmitter works at short range but not long range, replace battery. If that does not work, problem may be in remote.

Tarp system will not operate with remote.

A. If motor controller senses a fault 2 times consecutively in same direction, tarp direction must be reversed before trying again.

TROUBLESHOOTING CONTROL BOX

PROBLEM

After activating, Control Box LED flashes and system does not operate.

System will not operate with remote or toggle switch (**cannot** hear a clicking noise from inside Control Box).

System will not operate with remote or toggle switch (**can** hear a clicking noise from inside Control Box, but nothing happens).

Remote and toggle switch operate motor, however, tarp motor turns freely while tarp does not move.

Tarp system does not operate with toggle switch. Motor engages but stalls and system does not turn.

SOLUTION

A. Typically indicates a breaker issue. If breaker resets, try operating. If breaker does not reset, disconnect power, replace breaker and try activating again.

A. If system has a battery cutoff switch, ensure it is turned to "ON" position.

B. Verify correct system wiring. See Wiring Diagram in Control Box installation instructions.

C. Auto circuit breaker may have tripped. Wait several minutes and try again. If it still does not work, circuit breaker may have detected a continuous short and short must be repaired.

A. Verify Control Box receives a minimum of 12 volts from battery.

B. Verify at least 12 volts transmit to motor terminals. If Control Box receives 12 volts but does not transmit 12 volts, problem may be in Control Box.

C. Verify motor receives at least 12 volts (use caution around moving parts). If motor receives 12 volts and doesn't turn, problem may be in motor.

D. If Control Box transmits 12 volts to motor, and it does not receive 12 volts, problem may be wires connecting Control Box to motor.

A. Check pin connections in shaft between motor and roll tube. If missing, replace sheared bolt or pin with new clevis pin.

B. Check tarp system for damaged or misaligned parts and correct as needed.

C. Ensure tarp is free from obstruction.

A. Check conditions and alignment of system. Ensure there are no broken components or obstructions. Refer to system's manual.

MANUFACTURER'S LIMITED WARRANTY

Agri-Cover, Inc. extends the following one (1) year Limited Warranty on its AGRI-COVER™ Control Box and Remote Control to the original retail purchaser:

Agri-Cover, Inc. warrants AGRI-COVER™ Control Box and Remote Control to be free from defects in workmanship under normal use for one (1) year from date of manufacture unless accompanied by proof of purchase. This Limited Warranty does not cover any damage due to accident, abuse, misuse, alteration, neglect, improper installation, or ordinary wear and tear.

Agri-Cover, Inc.'s sole obligation under this Limited Warranty is limited to the repair or replacement, at its option, of defective parts only. No labor or service allowance is given or implied. IN NO EVENT SHALL AGRI-COVER, INC. BE LIABLE FOR INCIDENTAL, CONSEQUENTIAL, OR SPECIAL DAMAGES. AGRI-COVER, INC. EXPRESSLY DISCLAIMS ANY AND ALL IMPLIED WARRANTIES OF MERCHANTABILITY, AND THERE ARE NO WARRANTIES WHICH EXTEND BEYOND THE LIMITED WARRANTY DESCRIPTION CONTAINED HEREIN.

For warranty, have your serial number ready and call our Customer Service Department at 800-233-4655 to determine if only a replacement part is needed or if the AGRI-COVER™ Control Box and Remote Control needs to be returned for inspection and repair. Goods to be returned must have a pre-authorized RA # (Return Authorization Number) - obtained by calling the number above. Mark the number on the package and ship it freight prepaid to address below. Agri-Cover, Inc. will pay freight to return goods to sender.

This Limited Warranty gives you specific legal rights and you may have other rights, which vary, from state to state.

For replacement parts shop tarreplacementparts.com or call Customer Service at 800-233-4655.